

Approved 29/11/01

4Q2

0.55—7.5kW

D.C. MOTOR REGENERATIVE
SPEED CONTROLLER



CONTROL
TECHNIQUES

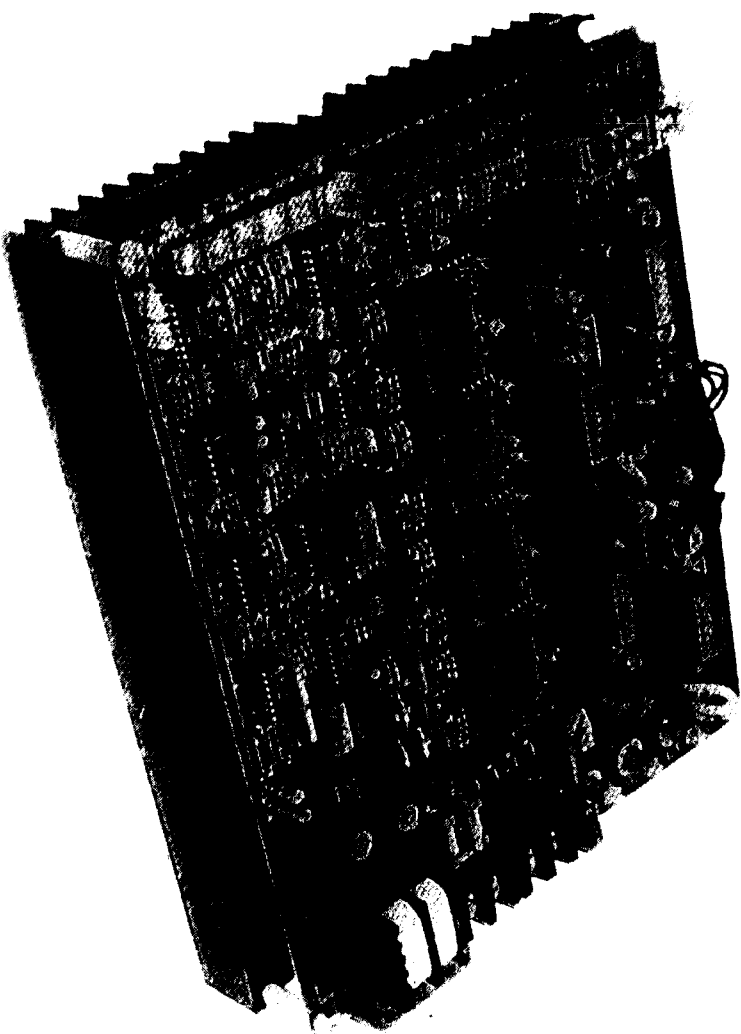

Instruction Manual



0176-7004

1. **GENERAL** Page

1.1 Description	1
1.2 Warning	1
1.3 Specification	1
1.4 Control Inputs	2
1.5 Control Outputs	2
1.6 Adjustments	3
1.7 Protection	3
1.8 Diagnostics	4

2. **INSTALLATION**

2.1 Electrical	6
2.2 Mechanical	6
2.3 Motor	7
2.4 Typical Connections	7
2.5 Motor Fuses	8

3. **STARTING AND ADJUSTING**

3.1 Control Selection	9
3.2 Switching On	10
3.3 Adjusting Presets	10
3.4 Reversing and Braking	11
3.5 Torque Control	12

4. **CIRCUIT & DESCRIPTION**

4.1 Block Diagram	13
4.2 Power Converter	14
4.3 Test Instrumentation	15

5. **FAULT FINDING**

5.1 Fault Finding Chart	16
-------------------------------	----

PLEASE READ THESE INSTRUCTIONS BEFORE INSTALLATION
IF IN DOUBT CONTACT YOUR SUPPLIER.

HEALTH AND SAFETY AT WORK
Electrical devices can constitute a safety hazard. It is the responsibility of the user to ensure the compliance of the installation with any acts or bylaws in force. Only skilled personnel should install this equipment after reading and understanding this instruction manual. If in doubt refer to your supplier.

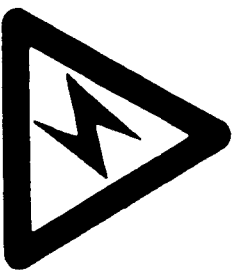

DANGER
ELECTRIC SHOCK RISK

Note: The contents of this manual are believed accurate at the time of printing. The manufacturers, however, reserve the right to change the content and product specification without notice.

Amendment to
Instruction Manual
4Q2 DC Motor Controller
(0176-7004 ref DCA 4/88)

- Page 1 - AC input current should read "40A" not "60A".
- Page 1 - AC input fuse rating should be "50A" not "80A".
- Page 5 - Add the statement "suitable for CE category 2 installations. If it is necessary to use the drive in category 3 installations, additional voltage suppression is required."
- Page 7 - Overhead Relay should read: "This is a Drive Status Relay which energises when the unit is ready to run, closing a N/O contact between terminal 2 & 3."
- Page 13 - Block diagram - Overhead Relay terminal connection numbers 1 and 3 should be swapped.

1. General

1.1 DESCRIPTION

The 4Q2 DC motor speed controller is designed to provide full four quadrant control of conventional shunt wound and permanent magnet motors up to 7.5kW capacity.

Units are suitable for operation on Line-Neutral supplies with 180V motors, and for Line-Line supplies with 320V motors.

The 4Q2 incorporates isolated control circuits for Armature Voltage and Tachogenerator feedback modes. Alternative connection arrangements provide for both speed or torque control with load sharing inputs and outputs available for interconnection between master and slave units.

A simple voltage selection link selects the 220/380/415 Volt tap on the power supply transformer and the motor voltage is selected by a selection link allowing flexible supply/motor voltage configurations.

The unit has both sub-cycle and delayed overload protection. With overload reset from an externally wired N/O pushbutton, or alternatively by removing the supply to the unit for one or two seconds.

Separate input terminals are provided for the mains power and the auxiliary electronic supply, allowing dual voltage operation of the power and electronic circuits and allowing the status relay to energise whilst the power circuits remain isolated.

The 4Q2 is supplied as a chassis module-IP00.

1.2 WARNING

Before selecting and fitting any links to the unit, ensure that the supply is disconnected. Although the input and output control terminals are isolated, parts of the units are live with respect to earth.

1.3 SPECIFICATION

Model	4Q2/30	4Q2/12
4Q2 O/P Amps average	30	12
A.C. Inputs, Amps RMS	60	25
A.C. Input Fuses (Amps)	80	32
220/240V Supply Motor kW	4.5	1.5
380/415V Supply Motor kW	7.5	2.75
Typical Watts Loss	100	50

Table 1:

Motor Voltage DC	V arm	V field
Supply 220/240V AC	180	190/210
Supply 380/415V AC	320	340/370

Table 2:

Supply Voltage
220/240 or 380 or 415 Volts AC \pm 10%, 50/60Hz.

Output Voltage
0 - 180V DC Armature 190/210V DC Field
0 - 320V DC Armature 340/370V DC Field

Enclosure
Chassis mounting, IP00.

Overload
150% of continuous current for 15 seconds.

Operating Temperature
Ambient not to exceed -10 to +40 degrees centigrade.

Humidity
85% R.H. at 40 degrees centigrade, non-condensing.

Altitude
Above 1000 metres de-rate by 1% 100 metres.

Control Method
Full wave fully controlled suppressed bridge with phase control, circulating current free.

Weight
3.6 Kg approx.

1.4 CONTROL INPUTS

Speed Reference 0/ \pm 10v
10K ohm Potentiometer
Direct speed reference Input impedance 30K ohms
Ramp speed reference Input impedance 30K ohms
Current reference Input impedance 20K ohms

Run/Inhibit
N/O contact closed to run, 0 to +10V logic level.

Torque Control
Two inputs available: I/P. 20K ohms.

Speed Feedback
Single input terminal linked for either Tachogenerator or Armature voltage feedback. Input impedance fixed for armature voltage feedback, must be matched to the tacho voltage where tachogenerator feedback is required.

1.5 CONTROL OUTPUTS

+10 Volts, 1 mA reference supply.
-10 Volts, 1mA reference supply.
Ramp generator output.
Speed error amplifier output (current demand)

Overload Relay

Change over contacts rated for 240V at 10A volt free. Relay energises on power up and de-energises on fault.

Low Speed Relay

Change over contacts rated for 240V at 10A volt free. De-energise at standstill.

1.8 DIAGNOSTICS

LED indication of:

Bridge A selected
Bridge B selected
Inhibit (Power On but drive inhibited ie. stand by).
Overload tripped

1.6 ADJUSTMENTS

Maximum Speed

Approximately 65-100% of maximum speed.

Minimum Speed

Approximately 0-50% of maximum speed.

Ramp Speed

Approximately 0.5 seconds to 15 seconds, linear. Identical acceleration and deceleration rates in both directions.

I R Compensation

Used to improve the speed regulation of the system when armature voltage feedback is used.

Current Limit

Approximately 0-150% of maximum current.

Stability

Optimises the drive stability for differing load conditions.

Terminal Links

Speed Error to Current Error . link Terminal 14 to 15. The Unit is delivered with this link fitted.

Voltage Selection Links

Wire link for 220/380/415 Volt supply selection. Selector link for 180/320 Volt motors.

Speed Calibration Resistor

When a tachogenerator is used to provide the feed back signal, the value of R6 must be selected to match the maximum full speed voltage of the tachog.

There is no requirement to set R6 when armature voltage feed back is selected.

Refer to section 3.1 for value of R6

1.7 PROTECTION

Individual device suppression components are fitted for each thyristor module together with mains suppression. Adjustable electronic current limit with timed and sub-cycle overload trip. The Overload latches out and may be reset by an external push button contact.

2. Installation

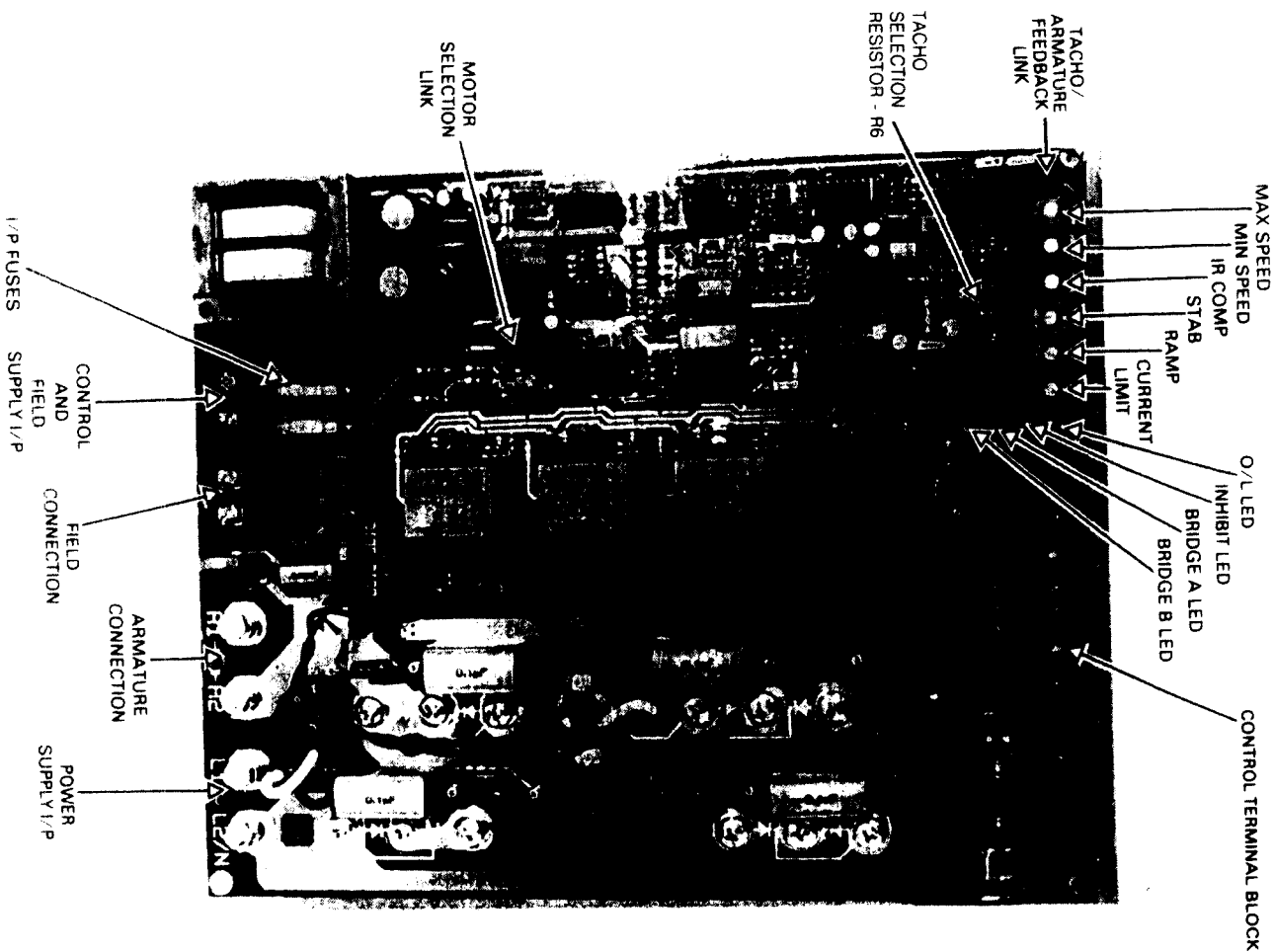

2.1 ELECTRICAL

Ensure that the 4Q2 is completely isolated from the electrical supply before working on the unit.

Power Cabling

Only use cable with the correct voltage and current rating. A minimum of 600V AC rating is recommended for the power circuits.

Fusing

The 4Q2 power circuit is not internally fused, all AC feeds and armature connections to the unit should be fuse protected.

Control Signal Cabling

All the control terminals of the 4Q2 unit are isolated from the internal power circuits. Signal cables should be screened and earthed near to the unit. It is advisable to segregate the signal cables from the power cables.

Overload Relay

This is a drive status relay which energises when the unit is ready to run, closing a N/O contact between Terminals 1 and 2. The overload may be reset after a trip by connecting a N/O push button contact between Terminals 20 and 21. The status contact may be used to operate the drive contactor.

Low Speed Relay

This relay is energised when the motor speed increases above a minimum low value. Its N/O contact between terminals 4 and 5 then closes.

Motor Chokes

When specified for certain motors DC chokes must be wired in series with the motor armature. (Refer to motor supplier).

2.2 MECHANICAL

The following general guidelines should be used when installing any electrical equipment:

1. Mount the unit for best heatsink air-flow i.e. fins vertical, see diag. below.
2. Mounting should be vibration free.
3. Ambient temperature should not exceed -10 to +40 C.
4. Unit should not be mounted in areas of direct sunlight.
5. Installation is free from dust, corrosive gas and grinding fluid.

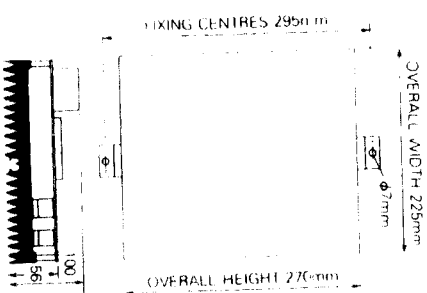

Enclosure: Allow 50mm either side and above, and 100mm top and bottom between unit and enclosure.

2.3 MOTOR

Foot mounted motors must be mounted on a level and rigid foundation and shims used where necessary to achieve this. During installation, all ventilation and conduit openings in the motor must be wrapped or otherwise protected against the ingress of dirt, moisture or other foreign matter. When fitting with couplings align the shaft to the driven machine to within +/- 0.25mm.

Do not hammer couplings or pulleys on to the shaft. Before running the drive complete the following checks:

1. With all 4Q2 connections removed, check the insulation resistance between all windings and earth, to make sure that the machine has not suffered any transit or storage damage.
2. Check that all brushes are seated correctly on the commutator, move freely in the brush holders and that all brush springs are securely in position.
3. Make sure all motor ventilation openings are clear.
4. Motor chokes when specified are correctly fitted.
5. Motor rotor is free moving within the restrictions of the connected load.

2.4 TYPICAL CONNECTIONS

CONTROL TERMINAL CONNECTIONS

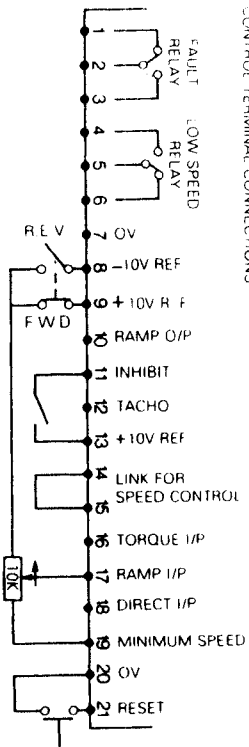

Armature voltage feedback with forward and reverse selection, and ramped input.

CONTROL TERMINAL CONNECTIONS

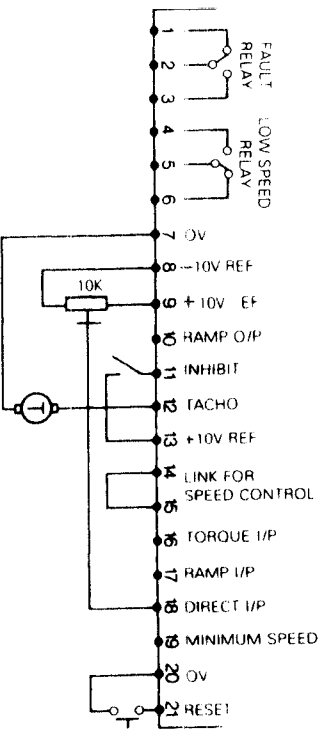

Tacho feedback with bidirectional control from the speed control potentiometer with direct input of reference signal (i.e. no ramp)

ARMATURE CONNECTIONS

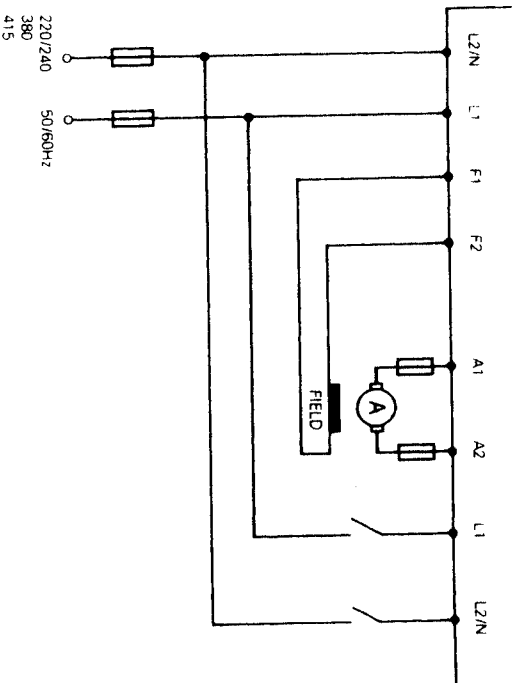

2.5 MOTOR FUSES

It is recommended that high speed fuses should be fitted in the armature leads.

I_{FL} value should be < 900 A/S.

Suitable types of fuses are detailed below:

Fuse Manufacturer			
4Q2	IR	GEC	FERRAZ
12A	E1000-20	GSG-1000/16	CPURE 20A
30A	E1000-40	GSG-1000/40	CPURE 40A
			A25X1-40

When used with 180V motors, fuses of a lower voltage rating may be able to be used, consult fuse manufacturer for alternatives.

3. Starting and Adjusting

WARNING

Although control inputs to the 4Q2 are isolated, certain areas of the circuitry are not. Exercise extreme caution when adjusting the unit and always isolate the equipment whilst setting voltage calibration links.

3.1 CONTROL SELECTION

Tacho/AVF Feedback

If armature voltage feedback is to be used ensure that the AVF link is in place on the circuit board. If tachogenerator feedback is required then reset this link to TG and connect the tacho between Terminals 7 and 12. The unit is feedback polarity dependant and hence only true DC tacho may be used. The tacho voltage must be arranged to be of opposite polarity to the reference voltage. If it is not possible to establish the tacho polarity then ensure that the maximum speed preset is turned fully anticlockwise before switching on. Failure to observe this precaution could result in the motor running into overspeed before the controller has been fully set up. When used with a tacho generator the feedback signal must be correctly calibrated to suit the voltage produced by the tacho at maximum motor speed. This is achieved by selection of resistor R6.

This resistor can be selected using the table below:

Tacho Volts at Max. Speed	R6 Value
20	22K
40	47K
60	68K
120	130K
180	200K

Speed/Torque Control

For normal operation as a speed controller, a link should be fitted between Terminals 14 and 15, where Torque control is required this link should be removed and the torque (current) reference signal input at terminal 16. The 4Q2 will produce zero to Full load current in both directions, under control of the current limit potentiometer, depending on the direction and level of the current reference signal. The current limit potentiometer may be used to limit the range of control available from the external current control element, the overload circuits will continue to operate in the normal manner if the final current demand exceeds 110% of the maximum current of the unit.

Motor Voltage Selection

Motor Voltage is selected by a link and should be positioned to suit the motor being used as shown in diagram.

Motor Voltage 320V



180V



Line Supply Voltage Selection
The voltage selection link adjacent to the transformer on the board must be set to the correct voltage position.

NOTE: It is essential that the supply to terminals L1-L2/N on the unit are maintained in phase with each other, although they do not necessarily have to be of the same potential.

3.2 SWITCHING ON

Before switching on ensure that the supplies to Terminals L1-L2/N are in Phase, reversal of phases will cause the unit to malfunction.

During initial switch on it is advisable to inhibit the controller by disconnecting the feed to Terminal 11, this will inhibit the controller and prevent energisation of the motor until the preliminary checks have been carried out.

When power is applied to the 4Q2 the inhibit LED and one of the bridge selection LEDs should illuminate.

Set the current limit potentiometer almost fully anti-clockwise (zero current) and make the connection to Terminal 11. The Inhibit LED should extinguish, apply a small speed reference signal from the speed control potentiometer.

The motor will start to turn and it's speed will increase until it matches the level set by the speed control potentiometer. If the unit is being used on armature voltage control the feedback polarity will be correct and control will be attained. Where a tachogenerator is employed, the motor may continue to accelerate with no control. If this is the case shut down and reverse the tachogenerator connections. If it is necessary to reverse the direction of rotation of the motor, remember that the tacho polarity must be reversed at the same time.

Once satisfactory operation has been achieved, adjust the speed reference level and check that the motor speed increases and decreases in response to changes in the speed reference setting.

3.3 ADJUSTING PRESETS

Maximum Speed

With the speed reference signal at maximum, adjust the maximum speed potentiometer to set the motor running at the required maximum speed. Ensure that the maximum motor armature voltage is not exceeded otherwise the unit will trip out. If the correct speed cannot be attained by adjustment of the maximum speed potentiometer, then check the value of R6 has not been correctly matched to the tachogenerator voltage.

If the motor speed is too high then the value of R6 must be reduced and conversely if the motor speed is too low then the value of the resistor should be increased.

Minimum Speed

With the speed control potentiometer set at zero adjust the minimum speed potentiometer to set the required minimum speed.

NOTE: If the main speed setting potentiometer is connected directly between the positive and negative reference supplies then the minimum speed potentiometer cannot be configured into the circuit.

Current Limit

This is used to set the maximum current which the motor can draw from the controller. Setting the potentiometer fully clockwise will provide up to 150% of the calibrated controller maximum current. (Either 18A or 45A).

The overload threshold is approximately 110% of this calibrated value and operation for prolonged periods at current levels above this figure will cause the unit to trip.

To reset the overload circuit and re-enable the status relay a normally open pushbutton should be connected between Terminals 20 and 21, or the power to the unit may be removed for 1 or 2 seconds.

Ramp Control

A single rate ramp generator is provided to set the acceleration and deceleration rates for the motor, the range is from 0.5 to 15 seconds. Clockwise rotation of potentiometer gives a faster acceleration rate ie. reduces the time.

IR Compensation

IR compensation may be used to improve the speed regulation of the motor against load when armature voltage feedback is used. To set up, the speed of the motor must be checked on no-load and full-load, the IR Comp potentiometer may then be used to reduce the speed droop as load is applied. Excessive IR compensation will cause the controller to become unstable.

When a tachogenerator is used the IR Comp potentiometer should be set fully anti-clockwise.

Stability

This potentiometer sets the response of the controller. It should be adjusted to give a smooth but rapid response to changes in speed demand. Generally low frequency oscillations require anti-clockwise adjustment.

3.4 REVERSING AND BRAKING

Because the 4Q2 is capable of controlling the motor in all four quadrants of operation, no additional equipment is necessary to achieve reverse operation or braking either to standstill or a lower speed. All reversing and braking operations can be performed directly under the control of the 4Q2 unit.

Reversing is simply achieved, by reversing the polarity of the speed reference signal.

Braking is performed by reducing the speed reference signal to the new required value, be it zero or some low intermediate setting. The 4Q2 will automatically reduce the motor speed to the required level by changing bridges to pass regenerative current until the new speed is reached.

3.5 TORQUE CONTROL

Because the armature current (torque) is exactly proportional to the voltage input at terminals 15 and 16, it is very simple to implement torque control on the 4Q2. A torque setting potentiometer should have its wiper connected to either of these inputs, bi-directional torque reference signals are accepted by the 4Q2.

External control of the current limit level is also possible by replacing the wire link between terminals 14 and 15 with a potentiometer connected as a potential divider to terminal 7 or 20 the zero volt connections.

4. Circuit & Description

4.1 BLOCK DIAGRAM

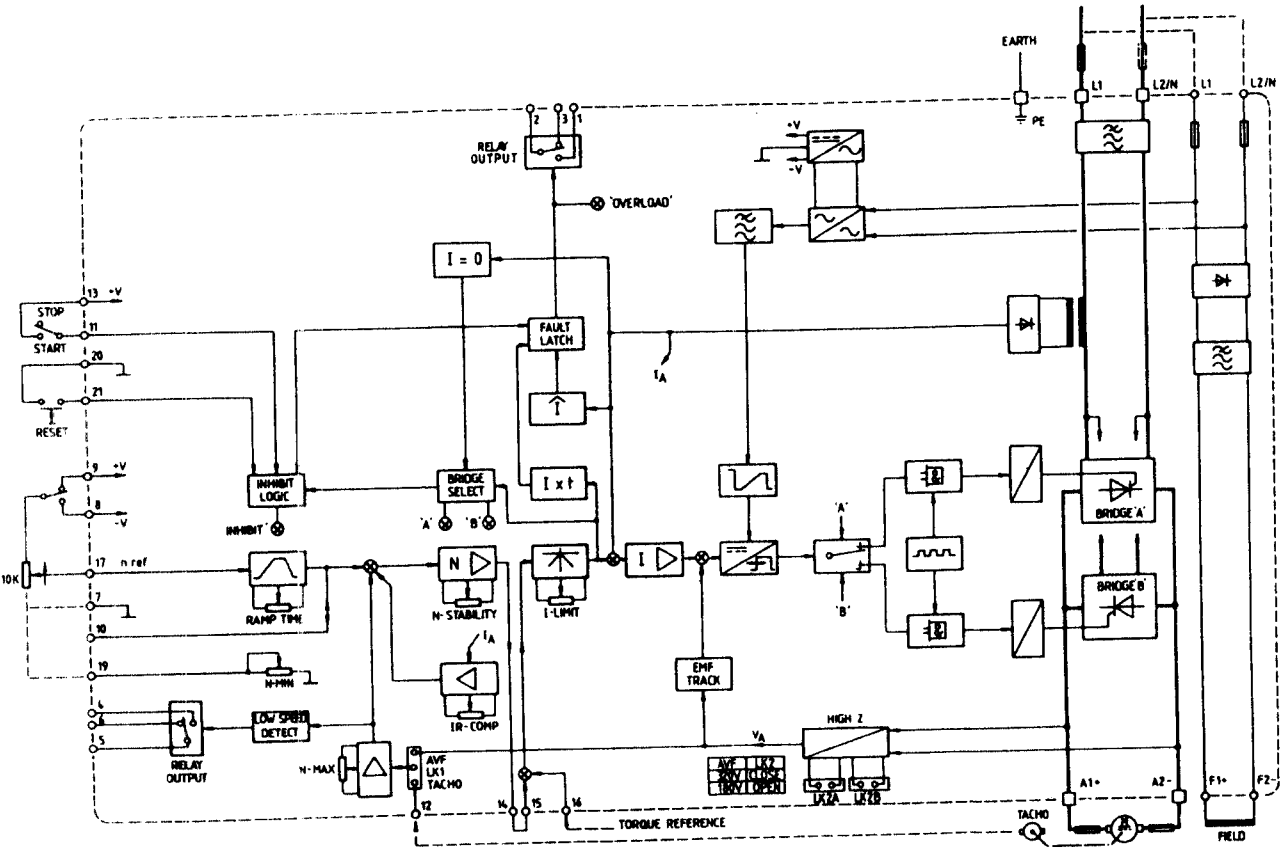

4.2 POWER CONVERTER

(i) Power Converter

Four dual thyristor modules are configured to form two fully controlled bridges. These are connected in anti-parallel. Each module is provided with an RC network to provide dv/dt protection and a varistor is connected across the incoming supply to suppress excessive transient voltages.

Motor current is monitored by an AC current transformer and armature voltage feedback is provided by a high impedance isolating circuit consisting of high impedance resistor network and buffer amplifier.

The thyristors are triggered by four dual secondary pulse transformers. The pulse transformers generate continuous DC block firing pulses so ensuring positive conduction of the thyristor under all conditions of rectification and inversion.

(ii) Power Supplies

Power for the electronic control circuits is supplied via the input transformer. The transformer has two centre tapped secondary windings providing a 100/0/100V synchronising signal for the thyristor trigger control circuits and a 20/0/20V supply rectified to produce an unregulated positive and negative 20V supply. Voltage regulators reduce these to produce stabilised positive and negative 15V supplies for the amplifier and logic circuits.

(iii) Phase Control

The output from the thyristor converters is adjusted by phase angle control. Two voltage comparators produce anti-phase firing signals when the DC level from the current control amplifier corresponds with the instantaneous value of the Cosine synchronising voltages.

The firing signals are steered by the steering logic and combined with a master oscillator frequency. The resulting signals then pass to the pulse transformer drive amplifiers. These amplifiers consist of pairs of complementary transistors connected to drive the pulse transformer primary winding with a high frequency AC square wave.

(iv) Speed Control

The speed reference signal may be obtained via the ramp or fed directly to the speed error amplifier via Terminal 18. The speed feedback signal is selected by a link for either tachogenerator or for the armature voltage monitoring signal.

The speed feedback voltage is calibrated by resistor R6. The speed control amplifier is a high gain amplifier giving accurate control of the motor speed especially when a quality Tacho is used. A resistor and capacitor network provides the stabilising term which is adjusted for optimum effect by the stability potentiometer. The output from the speed control amplifier is reduced to zero when the drive ramp is applied.

(v) Bridge Selection Logic

In order to achieve four quadrant operation the thyristor converter bridges must be selected depending upon the polarity of the speed error signal produced by the speed control amplifier. This reflects the required direction of current flow. A speed error polarity detector switches between two states, maximum positive or maximum negative.

5.1 The following chart is not exhaustive, but shows the general procedure to be adopted when fault finding.

Fault	Possible Cause	Action
Power on LED fails	Supply loss. Internal fuses blown	Replace fuses with identical type and manufacture and if fuses blow again replace drive.

(vi) Overload Protection

Both inverse time and instantaneous overload trips are incorporated to immediately trip the controller and disable the Status relay in the event of a fault.

The inverse time overload operates by monitoring the current demand level and comparing it against a preset threshold. If this level is exceeded then a voltage is produced which will start to rise at a rate proportional to the excess of current demand.

When this voltage reaches a set voltage it de-energises the status relay. The instantaneous overload monitors current level directly, any excessive fault current bypasses the inverse time overload circuit and instantly causes a trip. This is latched and holds the status relay out until reset.

4.3 TEST INSTRUMENTATION

Take care when connecting test instruments, although the control inputs of the 4Q2 are isolated, power circuits are not. Remember also that neither the 4Q2 output voltage or current are pure DC. This can give misleading results when using certain test instruments, in general though an electronic voltmeter will give reliable output voltage readings. Current readings taken from the AC supply will vary considerably from DC readings taken in the armature circuit. The relationship between the two varies with speed setting. Consequently when establishing motor load conditions it is best to measure DC armature current. A conventional "clip-on" test ammeter cannot be used for measuring the DC circuits; only use a true DC ammeter such as a Hall Effect probe.

Motor will not run inhibit LED on	External interlock open Overcurrent LED lights	Check motor connections for short circuit or ground fault. Check Armature fuses. Reset if overcurrent trip occurs again. Open circuit motor terminals reset. If fault remains replace drive.
Motor runs for a while and stops overload LED lights	No speed reference Incorrect current limit set Motor overloaded Field circuit faulty	Check voltage Ref's at terminal 8 and 9. Check overload setting adjust if necessary Check armature current with motor rating Check motor field voltage and current
Motor runs at full speed only	Open circuit speed control pot Faulty tachometer Tachometer polarity incorrect	Change control pot Check tachometer I/Ps Swap tachometer I/Ps
Drive unstable	Incorrect setting of stability pot Too much IR compensation	Adjust stability pot for optimum stability Adjust IR compensator pot